



Die breite Ausführungspalette und das besondere Design der "KURZHUBZYLINDER Serie W" von UNIVER erleichtern all jenen, die kompakte Druckluftzylinder von mechanischen verringerten Betriebshüben brauchen, die Wahl des richtigen Zylinders. Die verschiedenen verfügbaren Durchmesser und die Verwendung von mechanischen Endanschlägen, erlauben den Betrieb mit gefilterter und ungeölter Druckluft nach den europäischen Vorschriften für den Umweltschutz.

TECHNISCHE DATEN

Betriebsdruck: 1,5 ÷ 10 bar
 Umgebungstemperatur: -20 ÷ +80°C
 Medium: gefilterte, geölte oder ungeölte Druckluft

Konstruktionseigenschaften

Aluminiumlegierung, innen und außen eloxiert, 15-18 µm
 Zylinderköpfe demontierbar
 Kolben mit Permanentmagnetring aus Plastroferrit (auf Anfrage für Ø 16 ÷ 100)
 Kolbendichtung aus verschleißfester Nitrilmischung, geeignet für Betrieb mit oder ohne Schmierung, die Doppellippenform erlaubt eine konstante Verschleißrückgewinnung
 Kolbenstange aus gerolltem Edelstahl (AISI 303) mit Innengewinde (Nippel auf Anfrage)
 Führungsbüchse aus selbstschmierendem Material mit Endanschlag
 Magnetsensor Serie DH... (Abschnitt Zubehör Seite 2-3)

Nenntoleranz auf den Hub

Zyl. Ø	Toleranz mm
12 ÷ 25	+ 1,5/0
32 ÷ 50	+ 2/0
63 ÷ 100	+ 2,5/0

Sonderausführungen

- Hintere Gelenklasche
- Nippel
- Zylinder mit verdrehsicherer Kolbenstange (Ø 16 ÷ 100)
- Durchgehende hohle Kolbenstange (Ø 20 ÷ 100)
- Magnetversion (Ø 16 ÷ 100)
- Tandemzylinder
- Führungseinheit Ø 20 ÷ 80 (Abschnitt High-Tech Seite 46)

Entwickelte Kräfte

Sie werden nach den folgenden Formeln errechnet.

Schubkraft	Zugkraft
S = S · p · a	Z = s · p · a

- p = Speisungsdruck
- S = Schuboberfläche (cm²)
- s = Zugoberfläche (cm²)
- a = Reibung (10%)

Zyl. Ø	Ø Kolbenstange (mm)	S (cm ²)	s (cm ²)	Max. Federreaktionskraft (N)
12	6	1,1	0,8	6,8
16	6	2	1,7	7,8
20	10	3,1	2,3	13,2
25	10	4,9	4,1	19,6
32	12	8	6,9	35,3
40	16	12,6	10,6	45
50	16	19,6	17,6	70,5
63	20	31,1	28	96
80	25	50,3	54,3	119,5
100	25	78,5	73,6	237,2

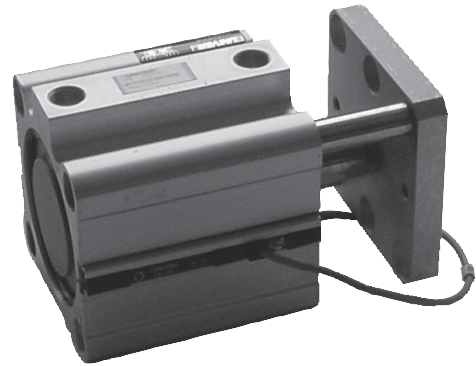

Typenschlüssel

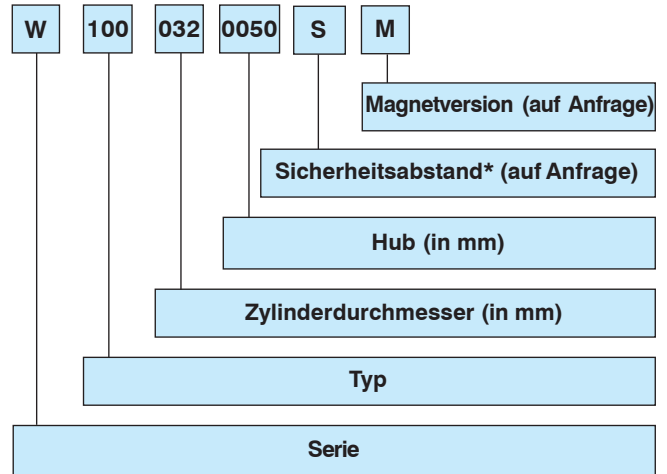

TYP

- 100 D.W.
- 101 D.W.durchgehende Kolbenstange
- 110 D.W.verdrehsichere Kolbenstange*
- 111 D.W.durchgehende verdrehsichere Kolbenstange*
- 131 D.W.durchgehende hohle Kolbenstange (ab Ø 20mm)
- 160 E.W.eingefahrene Kolbenstange
- 170 E.W.ausgefahrene Kolbenstange

VERSION MIT HINTERER GELENKLASCHE

- (nicht für Ø 12)
- 700 D.W.
- 760 E.W.eingefahrene Kolbenstange
- 770 E.W.ausgefahrene Kolbenstange

ZYLINDERDURCHMESSER

12 - 16 - 20 - 25 - 32 - 40 - 50 - 63 - 80 - 100 mm

STANDARDHÜBE

- Ø12 - 25 E.W.: 5 - 10 mm
- Ø32 - 100 E.W.: 5 - 10 - 25 mm
- Ø12 - 16 D.W.: 5 - 10 - 20 - 25 - 30 - 40 - 50 mm
- Ø20 - 100 D.W.: 5 - 10 - 20 - 25 - 30 - 40 - 50 - 75 mm

D.W. = doppelwirkend
 E.W. = einfachwirkend

* Die Ausführungen mit verdrehsicherer Kolbenstange können (auf Anfrage) mit Sicherheitsabstand gemäß der europäischen Normen EN 349 (Seiten 61-62) ausgestattet werden

Doppelwirkender Zylinder Serie W 100.. / W 100..M

Zylinder Ø 12

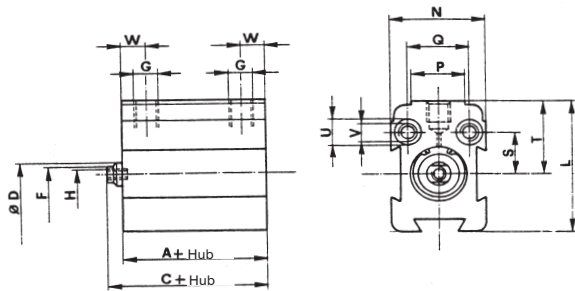
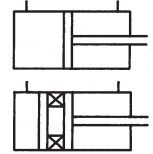

Zylinder Ø 16 ÷ 100

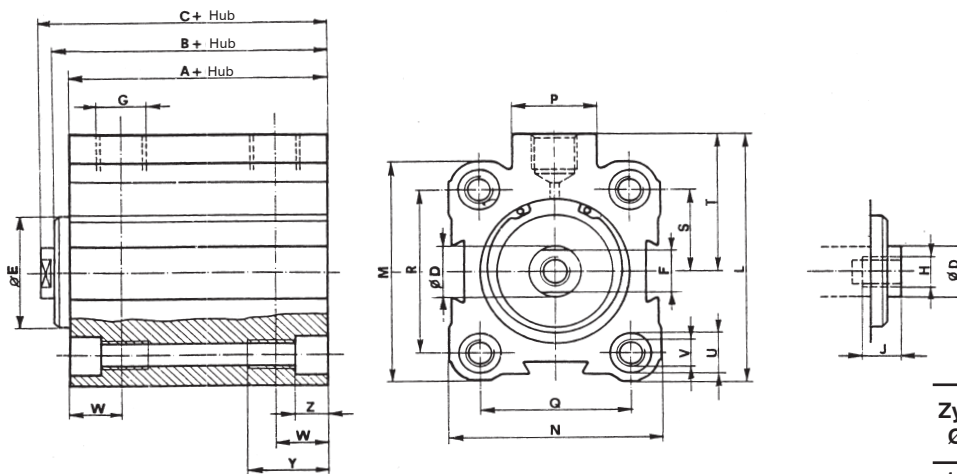

Masse

Zyl. Ø	Nicht magnetisch	Magnetisch	Zuschiag pro mm
12	0,045	-	1,2
16	0,074	0,102	1,4
20	0,095	0,12	2
25	0,135	0,155	2,85
32	0,233	0,292	4,06
40	0,394	0,43	5,47
50	0,39	0,446	6,4
63	0,64	0,772	9,7
80	1,19	1,275	14,85
100	1,72	1,92	19,7

Zyl. Ø	A	B	C + HUB			D	E	F	G	H	J	L	M	N	P	Q	R	S	T	U	V		W	Y	Z	
			A*	B*	C*																Bohrung	Gewinde				
12	32	-	35,5	-	-	6	-	5	M5	M3	6,5	28,5	-	20	11	13	-	9	16	6	3,7	M4	8,2	9	3,4	
16	32	-	35,5	42	-	45,5	6	-	5	M5	M3	6,5	31	28	28	11	20	20	10	17	5,8	3,7	M4	6,5	9	3,4
20	35	-	42	45	-	52	10	-	8	M5	M5	10	35	32	32	11	22	22	11	19	7,5	4,6	M5	7	10	4,6
25	35	-	42	45	-	52	10	-	8	G 1/8	M5	10	44,5	39	37	18	26	28	14	25	7,5	4,6	M5	7,5	10	4,6
32	37	42	49	47	52	59	12	23	10	G 1/8	M6	12	54	48	45	18	32	36	18	30	8,5	5,55	M6	9	16	5,7
40	40	47	55	45	52	60	16	29,5	13	G 1/8	M8	14	60	54,5	54,5	18	40	40	20	33	8,5	5,55	M6	9,5	16	5,7
50	40	46,5	55	45	51,5	60	16	35,5	13	G 1/4	M8	14	72	64	64	22	50	50	25	40	10,5	7,4	M8	10	16	6,8
63	42	50,5	59	47	55,5	64	20	43	17	G 1/4	M10	15	88	80	80	22	62	62	31	48	13,5	9,3	M10	10	20	9
80	52	60	71,5	57	65	76,5	25	50	22	G 3/8	M12	20	110	100	100	26	82	82	41	60	13,5	9,3	M10	15	20	9
100	52	60	71,5	57	65	76,5	25	56	22	G 3/8	M12	20	134	124	124	26	103	103	51,5	72	16,5	11,2	M12	15	25	11

* Magnetversion

Doppelwirkender Zylinder, durchgehende Kolbenstange Serie W 101.. / W 101..M

Zylinder Ø 12

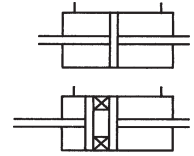
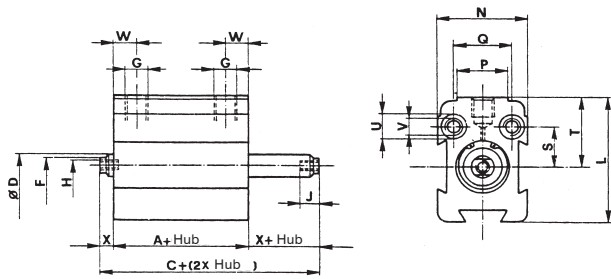

Masse

Zyl. Ø	Nicht magnetisch	Magnetisch	Zuschiag pro mm
12	0,055	-	1,4
16	0,086	0,114	1,6
20	0,112	0,137	2,65
25	0,165	0,185	3,5
32	0,295	0,354	5
40	0,5	0,536	7
50	0,478	0,534	8
63	0,79	0,922	12,2
80	1,345	1,43	18,7
100	1,875	2,075	23,6

Zylinder Ø 16 ÷ 100

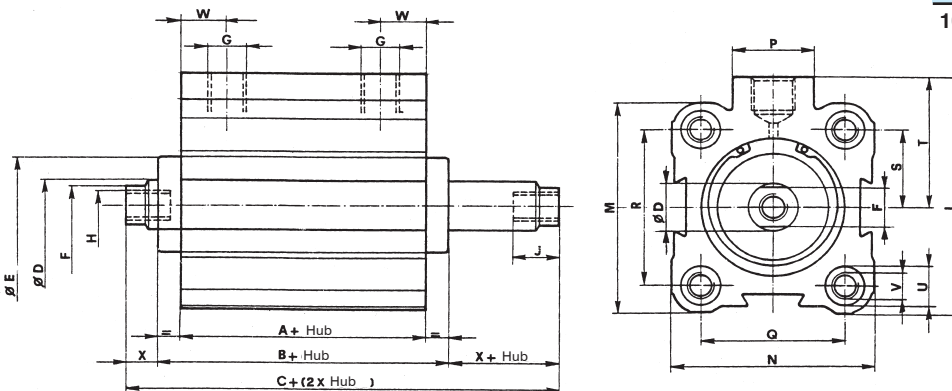

Doppelwirkender Zylinder, durchgehende - hohle Kolbenstange W 131.. / W 131..M

Für Ø 20 ÷ 100

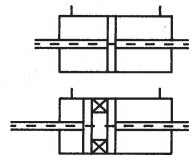
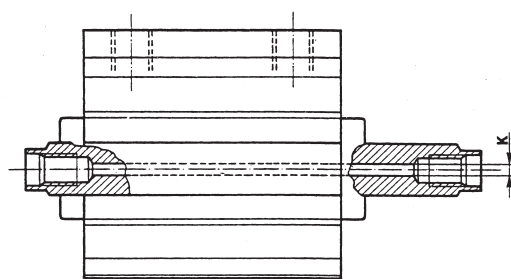

Zyl. Ø	12	16	20	25	32	40	50	63	80	100
K	-	-	2,5	2,5	3	4	4	6	6	6

Gewicht siehe obenstehende Tabelle

Zyl. Ø	A	B	C + HUB			D	E	F	G	H	J	L	M	N	P	Q	R	S	T	U	V		W	X	Y	Z	
			A*	B*	C*																Bohrung	Gewinde					
12	37	-	44	-	-	6	-	5	M5	M3	6,5	28,5	-	20	11	13	-	9	16	6	3,7	M4	8,2	3,5	9	3,4	
16	37	-	44	47	-	54	6	-	5	M5	M3	6,5	31	28	11	20	20	10	17	5,8	3,7	M4	6,5	3,5	9	3,4	
20	40	-	54	50	-	64	10	-	8	M5	M5	10	35	32	11	22	22	11	19	7,5	4,6	M5	7	7	10	4,6	
25	40	-	54	50	-	64	10	-	8	G 1/8	M5	10	44,5	39	37	18	26	28	14	25	7,5	4,6	M5	7,5	7	10	4,6
32	42	52	66	52	62	76	12	23	10	G 1/8	M6	12	54	48	45	18	32	36	18	30	8,5	5,55	M6	9	7	16	5,7
40	45	59	75	50	64	80	16	29,5	13	G 1/8	M8	14	60	54,5	54,5	18	40	40	20	33	8,5	5,55	M6	9,5	8	16	5,7
50	45	58	75	50	63	80	16	35,5	13	G 1/4	M8	14	72	64	64	22	50	50	25	40	10,5	7,4	M8	10	8,5	16	6,8
63	47	64	81	52	69	86	20	43	17	G 1/4	M10	15	88	80	80	22	62	62	31	48	13,5	9,3	M10	10	8,5	20	9
80	52	68	91	57	73	96	25	50	22	G 3/8	M12	20	110	100	100	26	82	82	41	60	13,5	9,3	M10	15	11,5	20	9
100	52	68	91	57	73	96	25	56	22	G 3/8	M12	20	134	124	124	26	103	103	51,5	72	16,5	11,2	M12	15	11,5	25	11

* Magnetversion



Einfachwirkender Zylinder, eingefahrene Kolbenstange Serie W 160.. / W 160..M

Zylinder Ø 12

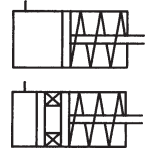
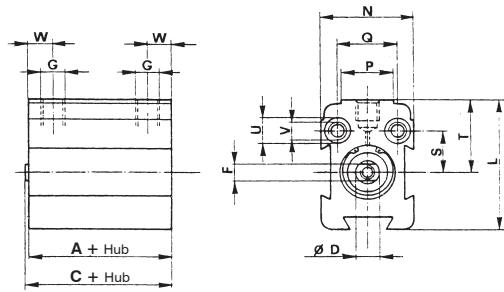

Zylinder Ø 16 ÷ 100

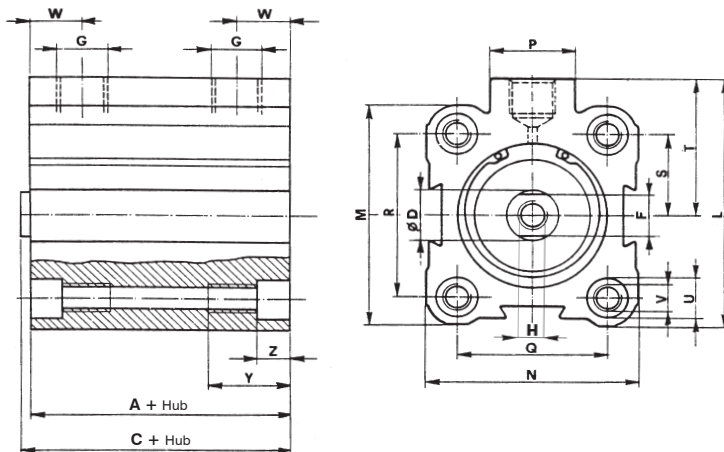

Masse

Zyl. Ø	Nicht magnetisch	Magnetisch	Zuschiag pro mm
12	0,038	-	1,2
16	0,059	0,079	1,4
20	0,07	0,095	2
25	0,096	0,116	2,85
32	0,194	0,253	4,06
40	0,326	0,362	5,47
50	0,322	0,378	6,4
63	0,533	0,715	9,7
80	1,02	1,105	14,85
100	1,49	1,69	19,7

Zyl. Ø	A C A* C*				D	F	G	H	J	L	M	N	P	Q	R	S	T	U	V		W	Y	Z
	+ HUB																		Bohrung	Gewinde			
12	27	28	-	-	6	5	M5	M3	6,5	28,5	-	20	11	13	-	9	16	6	3,7	M4	8,2	9	3,4
16	22	23	37	38	6	5	M5	M3	6,5	31	28	28	11	20	20	10	17	5,8	3,7	M4	6,5	9	3,4
20	25	26	40	41	10	8	M5	M5	10	35	32	32	11	22	22	11	19	7,5	4,6	M5	7	10	4,6
25	25	26	40	41	10	8	G 1/8	M5	10	44,5	39	37	18	26	28	14	25	7,5	4,6	M5	7,5	10	4,6
32	32	33	47	48	12	10	G 1/8	M6	12	54	48	45	18	32	36	18	30	8,5	5,55	M6	9	16	5,7
40	35	36	45	46	16	13	G 1/8	M8	14	60	54,5	54,5	18	40	40	20	33	8,5	5,55	M6	9,5	16	5,7
50	35	36	45	46	16	13	G 1/4	M8	14	72	64	64	22	50	50	25	40	10,5	7,4	M8	10	16	6,8
63	37	39	47	49	20	17	G 1/4	M10	15	88	80	80	22	62	62	31	48	13,5	9,3	M10	10	20	9
80	47	53	57	63	25	22	G 3/8	M12	20	110	100	100	26	82	82	41	60	13,5	9,3	M10	15	20	9
100	47	53	57	63	25	22	G 3/8	M12	20	134	124	124	26	103	103	51,5	72	16,5	11,2	M12	15	25	11

* Magnetversion



Einfachwirkende Zylinder, ausgefahrene Kolbenstange Serie W 170.. / W 170.. M

Zylinder Ø 12

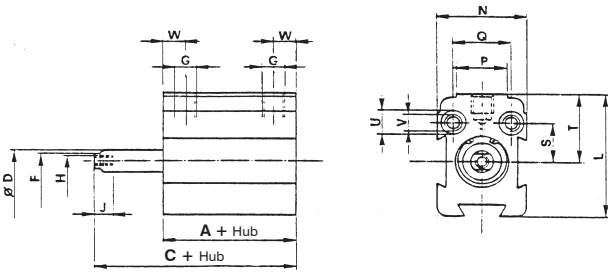
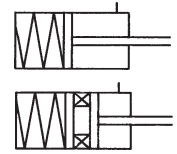

Zylinder Ø 16 ÷ 100

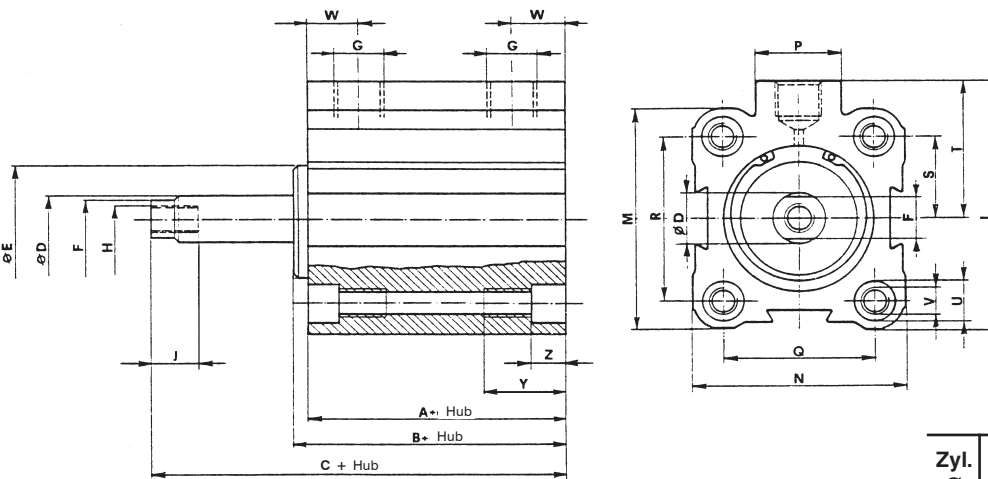

Masse

Zyl. Ø	Nicht magnetisch	Magnetisch	Zuschlag pro mm
12	0,045	-	1,2
16	0,7	0,098	1,4
20	0,86	0,111	2
25	0,122	0,142	2,85
32	0,212	0,271	4,06
40	0,366	0,402	5,47
50	0,352	0,408	6,4
63	0,59	0,772	9,7
80	1,104	1,189	14,85
100	1,576	1,776	19,7

Zyl. Ø	A	B	C	A*	B*	C*	D	E	F	G	H	J	L	M	N	P	Q	R	S	T	U	V		W	Y	Z
																						Bohrung	Gewinde			
12	32	-	35,5	-	-	-	6	-	5	M5	M3	6,5	28,5	-	20	11	13	-	9	16	6	3,7	M4	8,2	9	3,4
16	27	-	30,5	42	-	45,5	6	-	5	M5	M3	6,5	31	28	28	11	20	20	10	17	5,8	3,7	M4	6,5	9	3,4
20	30	-	37	45	-	52	10	-	8	M5	M5	10	35	32	32	11	22	22	11	19	7,5	4,6	M5	7	10	4,6
25	30	-	37	45	-	52	10	-	8	G 1/8	M5	10	44,5	39	37	18	26	28	14	25	7,5	4,6	M5	7,5	10	4,6
32	32	37	44	47	52	59	12	23	10	G 1/8	M6	12	54	48	45	18	32	36	18	30	8,5	5,55	M6	9	16	5,7
40	35	42	50	45	52	60	16	29,5	13	G 1/8	M8	14	60	54,5	54,5	18	40	40	20	33	8,5	5,55	M6	9,5	16	5,7
50	35	41,5	50	45	51,5	60	16	35,5	13	G 1/4	M8	14	72	64	64	22	50	50	25	40	10,5	7,4	M8	10	16	6,8
63	37	45,5	54	47	55,5	64	20	43	17	G 1/4	M10	15	88	80	80	22	62	62	31	48	13,5	9,3	M10	10	20	9
80	47	55	66,5	57	65	76,5	25	50	22	G 3/8	M12	20	110	100	100	26	82	82	41	60	13,5	9,3	M10	15	20	9
100	47	55	66,5	57	65	76,5	25	56	22	G 3/8	M12	20	134	124	124	26	103	103	51,5	72	16,5	11,2	M12	15	25	11

* Magnetversion

Verdrehsichere Kolbenstange
Serie W 110 .. / W 110 .. M

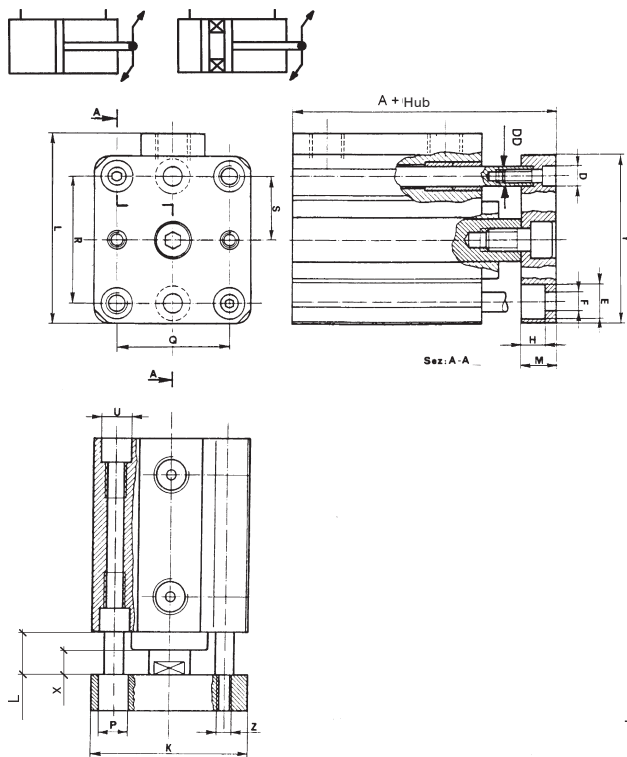

Durchgehende verdrehsichere Kolbenstange
Serie W 111 .. / W 111 .. M

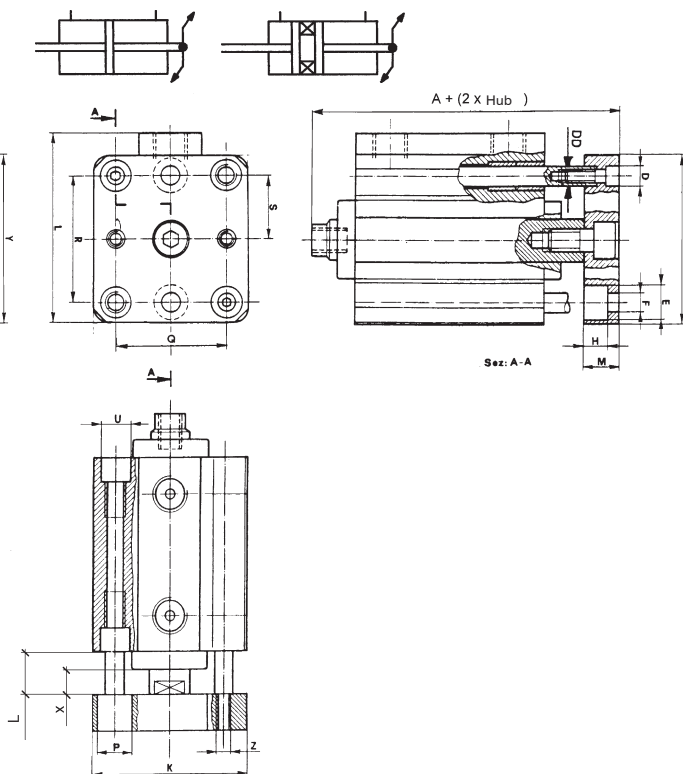

Verdrehsichere Kolbenstange
Serie W 110 .. S / W 110 .. SM

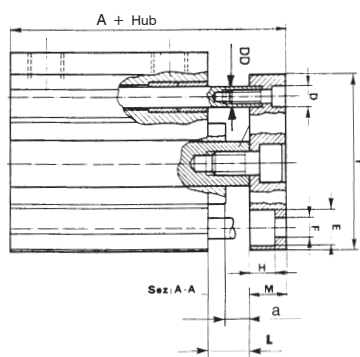
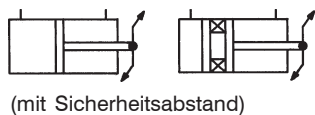

Durchgehende verdrehsichere Kolbenstange
Serie W 111 .. S / W 111 .. SM

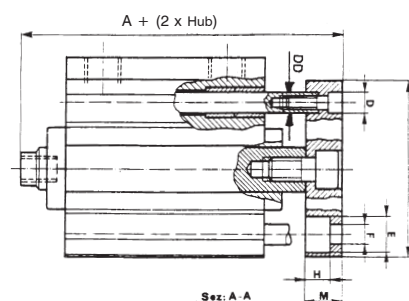
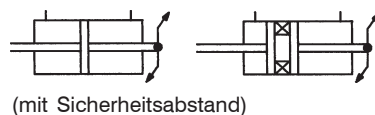

Masse

Zyl. Ø	Nicht magnetisch	Magnetisch	Zuschiag pro mm
16	0,092	0,12	1,6
20	0,133	0,158	2,45
25	0,185	0,205	3,3
32	0,33	0,39	4,85
40	0,545	0,58	6,7
50	0,6	0,656	7,6
63	0,96	1,092	11,5
80	1,75	1,835	17,25
100	2,63	2,83	22,8

Masse

Zyl. Ø	Nicht magnetisch	Magnetisch	Zuschiag pro mm
16	0,104	0,132	1,8
20	0,15	0,175	3,1
25	0,214	0,234	3,95
32	0,392	0,452	5,8
40	0,651	0,686	8,2
50	0,688	0,744	9,2
63	1,11	1,242	14
80	1,905	1,99	21
100	2,785	2,985	26,7

Diagramm Nutzlast/Überstand

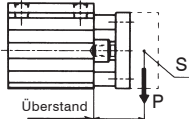

S = Nutzlastschwerpunkt
P = Nutzlast (N)

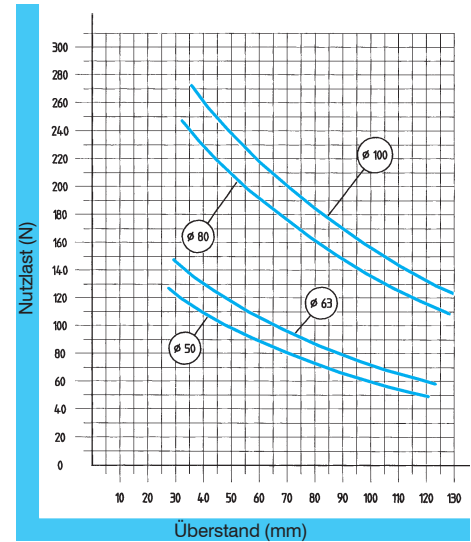
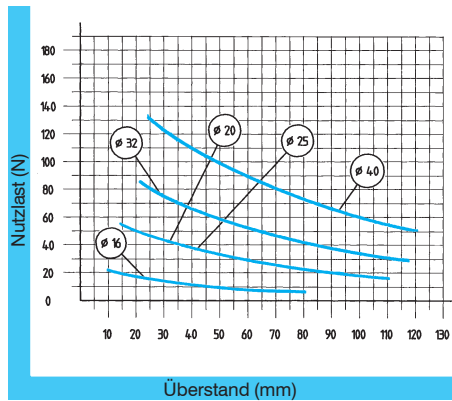

Maximale Abmessungen, Zylinder mit verdrehsicherer Kolbenstange

Zyl. Ø	X	L	W110 A + Hub	W111 A + (2 x Hub)	W110M A* + Hub	W111M A* + (2 x Hub)	D	DD	E	F	H	K	M	P	Q	R	S	Y	Z
16	3,5	3,5	42,5	51	52,5	61	6	4	6	3,5	3,5	27,5	7	6	20	20	10	27,5	M3
20	7	7	50	62	60	72	7,5	6	7,5	4,5	4,5	31,5	8	7,5	22	22	11	31,5	M4
25	7	7	50	62	60	72	7,5	6	7,5	4,5	5	36	8	7,5	26	28	14	38	M4
32	7	12	59	76	69	86	9	8	10	5,5	6	44,5	10	10	32	36	18	47,5	M4
40	8	15	65	85	70	90	10,5	10	10	5,5	6	53,5	10	10	40	40	20	53,5	M5
50	8,5	15	67	87	72	92	10,5	10	11	6,5	7	63,5	12	11	50	50	25	63,5	M6
63	8,5	17	71	93	76	98	13,5	12	14	9	9	79,5	12	15	62	62	31	79,5	M6
80	11,5	19,5	85,5	105	90,5	110	13,5	14	14	9	9	99,5	14	15	82	82	41	99,5	M8
100	11,5	19,5	87,5	107	92,5	112	16,5	16	16,5	10,5	10,5	123,5	16	17	103	103	51,5	123,5	M8

* Magnetversion

Maximale Abmessungen, Zylinder mit verdrehsicherer Kolbenstange und Sicherheitsabstand

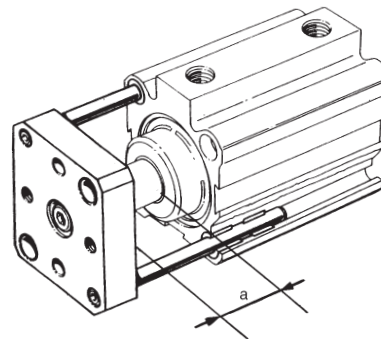

Zyl. Ø	W110 A + Hub	W111 A + (2 x Hub)	W110M A* + Hub	W111M A* + (2 x Hub)	L	a
16	67,5	76	77,5	86	28,5	28,5
20	70	82	80	92	27	27
25	70	82	80	92	27	27
32	79	96	89	106	32	27
40	85	105	90	110	35	28
50	87	107	92	112	35	28,5
63	91	113	96	118	37	28,5
80	100,5	120	105,5	125	34,5	26,5
100	102,5	122	107,5	127	34,5	26,5

Sicherheitsabstand zur Vermeidung von Unfällen gemäß EURO-Norm EN349

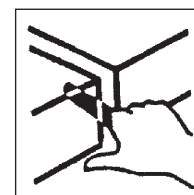

* Magnetversion

ANMERKUNG: für fehlende Werte siehe Versionen ohne Verdrehsicherung

Tandemzylinder

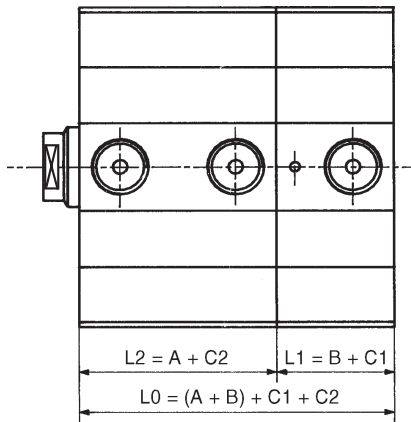
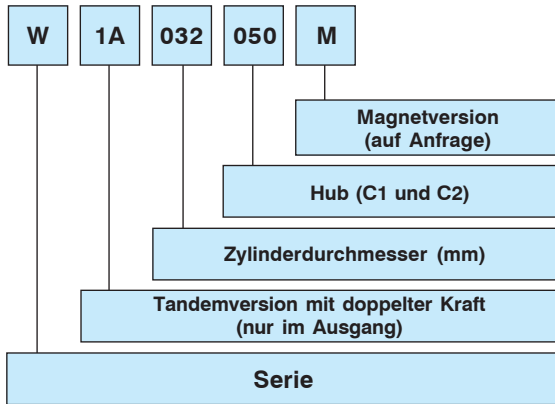
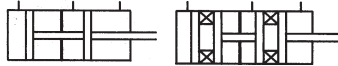

Tandem-Kurzhubzylinder "Serie W"

Zyl. Ø	L2 = A + C2	L1 = B + C1	L0 = (A+B) + C1 + C2
16	L2 = 37 + C2	L1 = 22 + C1	L0 = 59 + C1 + C2
20	L2 = 40 + C2	L1 = 25 + C1	L0 = 65 + C1 + C2
25	L2 = 40 + C2	L1 = 25 + C1	L0 = 65 + C1 + C2
32	L2 = 42 + C2	L1 = 23 + C1	L0 = 65 + C1 + C2
40	L2 = 45 + C2	L1 = 26,5 + C1	L0 = 71,5 + C1 + C2
50	L2 = 45 + C2	L1 = 26 + C1	L0 = 71 + C1 + C2
63	L2 = 47 + C2	L1 = 29 + C1	L0 = 76 + C1 + C2
80	L2 = 52 + C2	L1 = 38 + C1	L0 = 90 + C1 + C2
100	L2 = 52 + C2	L1 = 38 + C1	L0 = 90 + C1 + C2

Tandem-Kurzhubzylinder "Serie W" Magnetversion

Zyl. Ø	L2 = A + C2	L1 = B + C1	L0 = (A+B) + C1 + C2
16	L2 = 47 + C2	L1 = 37 + C1	L0 = 84 + C1 + C2
20	L2 = 50 + C2	L1 = 40 + C1	L0 = 90 + C1 + C2
25	L2 = 50 + C2	L1 = 40 + C1	L0 = 90 + C1 + C2
32	L2 = 52 + C2	L1 = 38 + C1	L0 = 90 + C1 + C2
40	L2 = 50 + C2	L1 = 36,5 + C1	L0 = 86,5 + C1 + C2
50	L2 = 50 + C2	L1 = 36 + C1	L0 = 86 + C1 + C2
63	L2 = 52 + C2	L1 = 39 + C1	L0 = 91 + C1 + C2
80	L2 = 57 + C2	L1 = 48 + C1	L0 = 105 + C1 + C2
100	L2 = 57 + C2	L1 = 48 + C1	L0 = 105 + C1 + C2

Doppelstellungs-Tandemzylinder

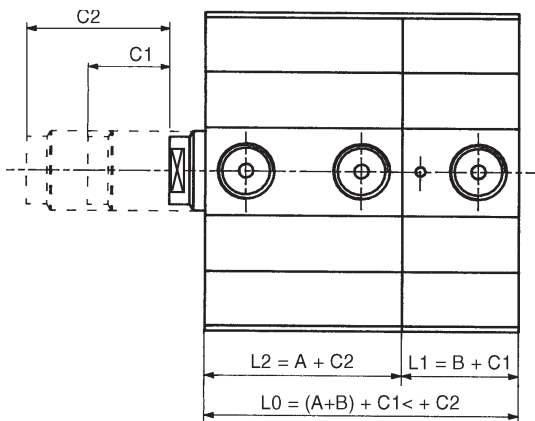
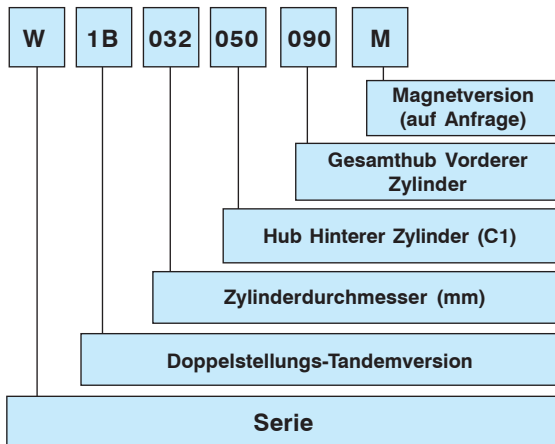

Hub C1 ist immer kürzer als Hub C2

Doppelstellungs-Kurzhubzylinder "Serie W"

Zyl. Ø	L2 = A + C2	L1 = B + C1	L0 = (A+B) + C1 + C2
16	L2 = 37 + C2	L1 = 22 + C1	L0 = 59 + C1 + C2
20	L2 = 40 + C2	L1 = 25 + C1	L0 = 65 + C1 + C2
25	L2 = 40 + C2	L1 = 25 + C1	L0 = 65 + C1 + C2
32	L2 = 42 + C2	L1 = 23 + C1	L0 = 65 + C1 + C2
40	L2 = 45 + C2	L1 = 26,5 + C1	L0 = 71,5 + C1 + C2
50	L2 = 45 + C2	L1 = 26 + C1	L0 = 71 + C1 + C2
63	L2 = 47 + C2	L1 = 29 + C1	L0 = 76 + C1 + C2
80	L2 = 52 + C2	L1 = 38 + C1	L0 = 90 + C1 + C2
100	L2 = 52 + C2	L1 = 38 + C1	L0 = 90 + C1 + C2

Doppelstellungs-Kurzhubzylinder "Serie W" Magnetversion

Zyl. Ø	L2 = A + C2	L1 = B + C1	L0 = (A+B) + C1 + C2
16	L2 = 47 + C2	L1 = 37 + C1	L0 = 84 + C1 + C2
20	L2 = 50 + C2	L1 = 40 + C1	L0 = 90 + C1 + C2
25	L2 = 50 + C2	L1 = 40 + C1	L0 = 90 + C1 + C2
32	L2 = 52 + C2	L1 = 38 + C1	L0 = 90 + C1 + C2
40	L2 = 50 + C2	L1 = 36,5 + C1	L0 = 86,5 + C1 + C2
50	L2 = 50 + C2	L1 = 36 + C1	L0 = 86 + C1 + C2
63	L2 = 52 + C2	L1 = 39 + C1	L0 = 91 + C1 + C2
80	L2 = 57 + C2	L1 = 48 + C1	L0 = 105 + C1 + C2
100	L2 = 57 + C2	L1 = 48 + C1	L0 = 105 + C1 + C2

Mehrstellungszyylinder WS (Typenbezeichnung entsprechend der Anwendung)

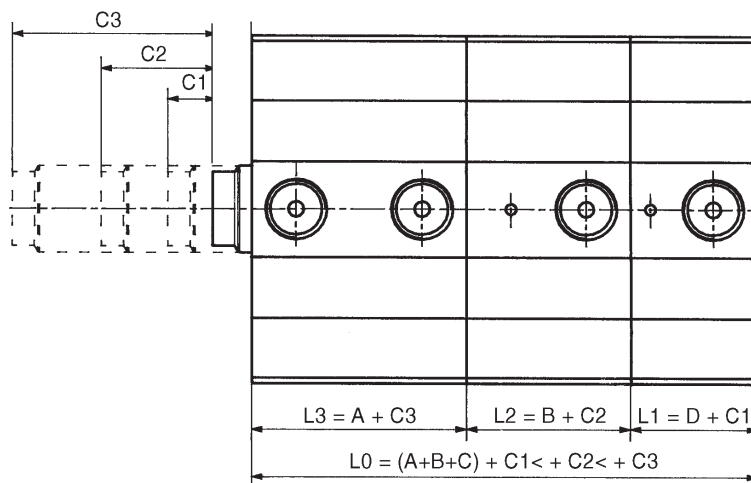
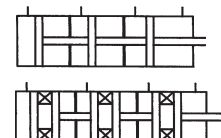

Mehrstellungs-Kurzhubzylinder "Serie W"

Zyl. Ø	$L3 = A + C3$	$L2 = B + C2$	$L1 = D + C1$	$L0 = (A+B+D) + C1< + C2< + C3$
16	$L3 = 37 + C3$	$L2 = 27 + C2$	$L1 = 22 + C1$	$L0 = 86 + C1< + C2< + C3$
20	$L3 = 40 + C3$	$L2 = 30 + C2$	$L1 = 25 + C1$	$L0 = 95 + C1< + C2< + C3$
25	$L3 = 40 + C3$	$L2 = 30 + C2$	$L1 = 25 + C1$	$L0 = 95 + C1< + C2< + C3$
32	$L3 = 42 + C3$	$L2 = 28 + C2$	$L1 = 23 + C1$	$L0 = 93 + C1< + C2< + C3$
40	$L3 = 45 + C3$	$L2 = 31,5 + C2$	$L1 = 26,5 + C1$	$L0 = 103 + C1< + C2< + C3$
50	$L3 = 45 + C3$	$L2 = 31 + C2$	$L1 = 26 + C1$	$L0 = 102 + C1< + C2< + C3$
63	$L3 = 47 + C3$	$L2 = 36 + C2$	$L1 = 29 + C1$	$L0 = 112 + C1< + C2< + C3$
80	$L3 = 52 + C3$	$L2 = 38 + C2$	$L1 = 38 + C1$	$L0 = 128 + C1< + C2< + C3$
100	$L3 = 52 + C3$	$L2 = 38 + C2$	$L1 = 38 + C1$	$L0 = 128 + C1< + C2< + C3$

Mehrstellungs-Kurzhubzylinder "Serie W" Magnetversion

Zyl. Ø	$L3 = A + C3$	$L2 = B + C2$	$L1 = D + C1$	$L0 = (A+B+D) + C1< + C2< + C3$
16	$L3 = 47 + C3$	$L2 = 42 + C2$	$L1 = 37 + C1$	$L0 = 126 + C1< + C2< + C3$
20	$L3 = 50 + C3$	$L2 = 45 + C2$	$L1 = 40 + C1$	$L0 = 135 + C1< + C2< + C3$
25	$L3 = 50 + C3$	$L2 = 45 + C2$	$L1 = 40 + C1$	$L0 = 135 + C1< + C2< + C3$
32	$L3 = 52 + C3$	$L2 = 43 + C2$	$L1 = 38 + C1$	$L0 = 133 + C1< + C2< + C3$
40	$L3 = 50 + C3$	$L2 = 41,5 + C2$	$L1 = 36,5 + C1$	$L0 = 128 + C1< + C2< + C3$
50	$L3 = 50 + C3$	$L2 = 41 + C2$	$L1 = 36 + C1$	$L0 = 127 + C1< + C2< + C3$
63	$L3 = 52 + C3$	$L2 = 44 + C2$	$L1 = 39 + C1$	$L0 = 135 + C1< + C2< + C3$
80	$L3 = 57 + C3$	$L2 = 48 + C2$	$L1 = 48 + C1$	$L0 = 153 + C1< + C2< + C3$
100	$L3 = 57 + C3$	$L2 = 48 + C2$	$L1 = 48 + C1$	$L0 = 153 + C1< + C2< + C3$

ANMERKUNG: auch in Version mit drehbarer Kolbenstange erhältlich. Für fehlende Abmessungen siehe Seite 56, Serie W100



Hinterre Gelenklasche

Serie W 700 ... / W 700 ... M

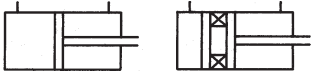

Serie W 760 ... / W 760 ... M

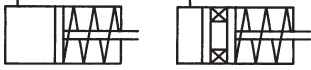

Serie W 770 ... / W 770 ... M

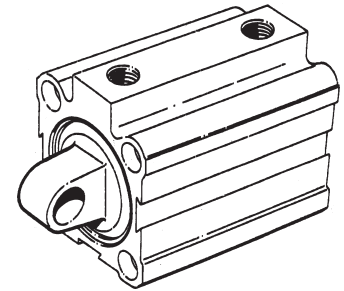
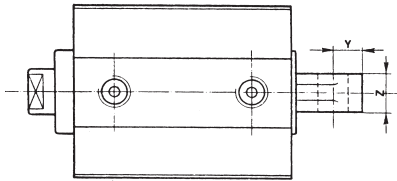
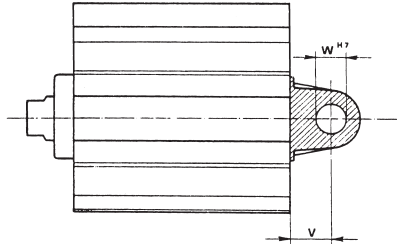
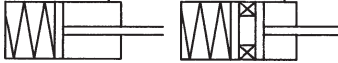

Masse

Zyl. Ø	W700.../W700...M			W760.../W760...M			W770.../W770...M		
	Nicht magnetisch Hub "0" Kg	Magnetisch Hub "0" Kg	Zuschiag pro mm gr	Nicht magnetisch Hub "0" Kg	Magnetisch Hub "0" Kg	Zuschiag pro mm gr	Nicht magnetisch Hub "0" Kg	Magnetisch Hub "0" Kg	Zuschiag pro mm gr
12	-	-	-	-	-	-	-	-	-
16	0,082	0,11	1,4	0,067	0,087	1,4	0,078	0,106	1,4
20	0,1075	0,1325	2	0,0825	0,0975	2	0,0985	0,1235	2
25	0,1585	0,1785	2,85	0,119	0,139	2,85	0,145	0,165	2,85
32	0,2765	0,3355	4,06	0,2375	0,2965	4,06	0,2555	0,3155	4,06
40	0,4705	0,5065	5,47	0,4025	0,4385	5,47	0,442	0,4785	5,47
50	0,417	0,473	6,4	0,349	0,405	6,4	0,379	0,435	6,4
63	0,6815	0,8135	9,7	0,5745	0,7565	9,7	0,6315	0,9135	9,7
80	1,2385	1,3235	14,85	1,0685	1,1535	14,85	1,1525	1,2375	14,85
100	1,775	1,975	19,7	1,545	1,745	19,7	1,631	1,831	19,7

Zyl. Ø	Y	Z	Ø W	V
12	-	-	-	-
16	5,5	9	6	6,2
20	5,5	9	6	6,5
25	6	12	6	8
32	9	14	10	11
40	10	16	12	13
50	12	17	12	16,5
63	14	21	16	18
80	14	21	16	16,5
100	17	25	20	21

Befestigungsschrauben

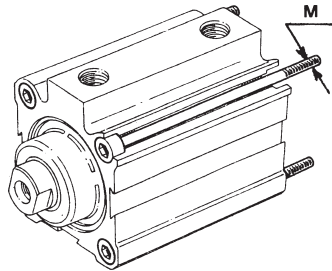

Zyl. Ø	12	16*	20	25	32	40	50	63	80	100
M	3	3	4	4	5	5	6	8	8	10

Nippel

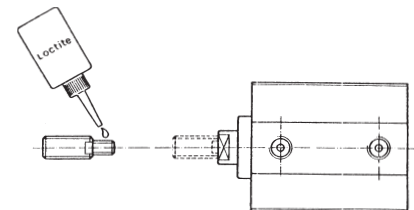
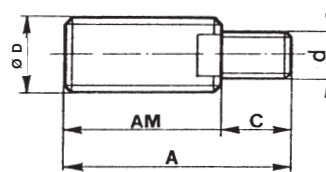

Zyl. Ø	A	AM	C	D	d	Artikelnr.
12-16	22,5	16	6,5	6 x 1	M 3	WF-50012
20-25	30	20	10	8 x 1,25	M 5	WF-50020
32	34	22	12	10 x 1,25	M 6	WF-50032
40	38	24	14	12 x 1,25	M 8	WF-50040
50	46	32	14	16 x 1,5	M 8	WF-50050
63	47	32	15	16 x 1,5	M 10	WF-50063
80-100	60	40	20	20 x 1,5	M 12	WF-50080

ANMERKUNG: nur bei Magnetversion, Ø 16, sind nicht-magnetische Befestigungsschrauben zu verwenden